

Operating Instructions

RI FB PRO/i
RI MOD/i CC EtherCAT

DE | Bedienungsanleitung

EN-US | Operating instructions



Inhaltsverzeichnis

Allgemeines	4
Sicherheit	4
Anschlüsse und Anzeigen.....	4
Eigenschaften der Datenübertragung	5
Konfigurationsparameter.....	6
Vergabe der EtherCAT-Adresse.....	6
Prozessdaten-Breite des Busmoduls einstellen.....	7
Prozessdaten-Breite des Busmoduls einstellen.....	7
Ein- und Ausgangssignale.....	8
Datentypen.....	8
Verfügbarkeit der Eingangssignale	8
Eingangssignale (vom Roboter zur Stromquelle).....	8
Wertebereich Working mode	13
Wertebereich Documentation mode.....	13
Wertebereich Process controlled correction.....	14
Wertebereich Processline selection.....	14
Wertebereich TWIN mode.....	14
Verfügbarkeit der Ausgangssignale	15
Ausgangssignale (von der Stromquelle zum Roboter)	15
Zuordnung Sensorstatus 1-4.....	18
Wertebereich Safety status	18
Wertebereich Process Bit.....	19

Allgemeines

Sicherheit

WARNUNG!

Gefahr durch Fehlbedienung und fehlerhaft durchgeführte Arbeiten.

Schwere Personen- und Sachschäden können die Folge sein.

- ▶ Alle in diesem Dokument beschriebenen Arbeiten und Funktionen dürfen nur von technisch geschultem Fachpersonal ausgeführt werden.
- ▶ Dieses Dokument vollständig lesen und verstehen.
- ▶ Sämtliche Sicherheitsvorschriften und Benutzerdokumentationen dieses Gerätes und aller Systemkomponenten lesen und verstehen.

Anschlüsse und Anzeigen

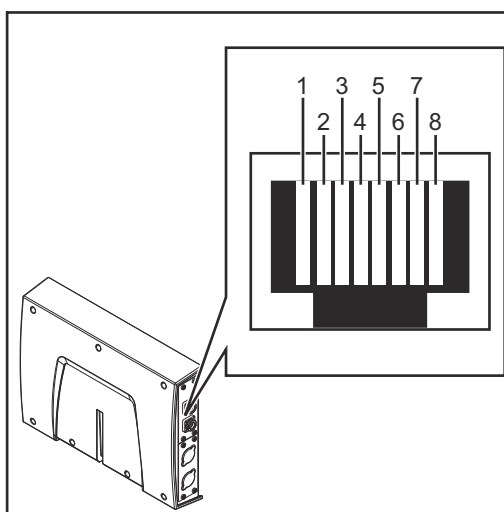

Pin-Belegung RJ 45 ProfiNet Anschluss

1	TX+
2	TX-
3	RX+
6	RX-
4,5,7,8	Normalerweise nicht verwendet; um die Signalfullständigkeit sicherzustellen, sind diese Pins miteinander verbunden und enden über einen Filterkreis am Schutzleiter (PE).

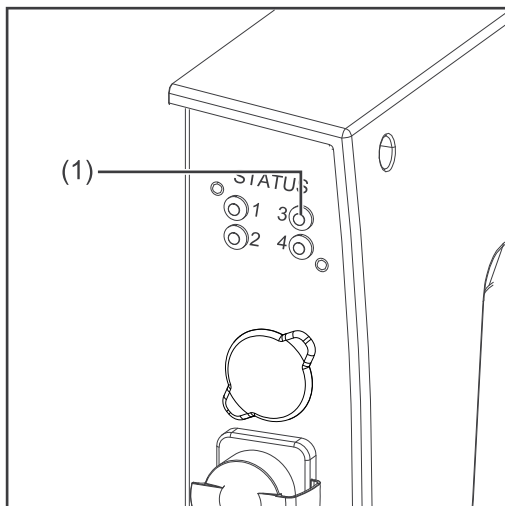

(1) LED RUN - Betrieb
Diese LED gibt den Status der CoE Kommunikation wieder. (CoE = CANopen over EtherCAT)

Aus:

CoE Gerät im Status 'init' (oder keine Versorgungsspannung)

Leuchtet grün:

CoE Gerät im Status 'operational'

Blinkt grün:

CoE Gerät im Status 'pre-operational'

Blinkt grün (kurz):

CoE Gerät im Status 'safe-operational'

Leuchtet rot:

Wenn die LEDs RUN und ERR leuchten, zeigt das ein schwerwiegendes Ereignis an, welches das Interface in einen Ausnahmezustand bringt. In diesem Fall den Servicedienst verständigen.

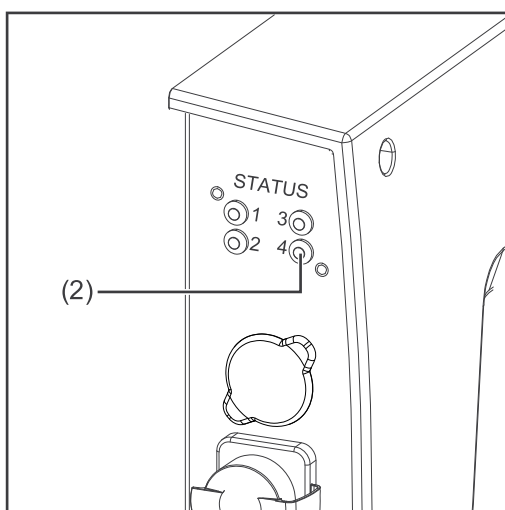

(2) LED ERR - Fehler

Aus:

keine Fehler (oder keine Versorgungsspannung)

Blinkt rot:

falsche Konfiguration
Vom Master empfangener Statuswechsel ist nicht möglich wegen ungültiger Register- oder Objekteinstellungen

Blinkt rot (doppelt):

Application watchdog timeout
Syn manager watchdog timeout

Leuchtet rot:

Application controller failure
Anybus Modul in EXCEPTION

Eigenschaften der Datenübertragung

Übertragungstechnik:

EtherCAT

Medium:

Bei der Auswahl der Kabel, Stecker und Abschluss-Widerstände ist die IEC 61784-5-12 für die Planung und Installation von EtherCAT Systemen zu beachten.

Seitens Hersteller wurden die EMV-Tests mit einem original Beckhoff-Kabel (ZK1090-9191-xxxx) durchgeführt.

Übertragungs-Geschwindigkeit:100 Mbit/s

Busanschluss:RJ-45 Ethernet

Application Layer:CANopen

Konfigurationsparameter

Bei einigen Robotersteuerungen kann es erforderlich sein die hier beschriebenen Konfigurationsparameter anzugeben, damit das Busmodul mit dem Roboter kommunizieren kann.

Parameter	Wert	Beschreibung
Vendor ID	0000 02C1 _{hex} (705 _{dez})	Fronius International GmbH
Product Code	0001 0322 _{hex} (66338 _{dez}) 0001 0321 _{hex} (66337 _{dez})	Standard Image Economy Image
Device Name		Fronius-RI-FB-Pro-EtherCAT

Vergabe der EtherCAT-Adresse

Die EtherCAT-Adresse wird vom Master vergeben.

Prozessdaten-Breite des Busmoduls einstellen

Prozessdaten-Breite des Busmoduls einstellen

IP-Adresse der verwendeten Stromquelle notieren:

- 1 Am Bedienpanel der Stromquelle „Voreinstellungen“ auswählen
- 2 Am Bedienpanel der Stromquelle „System“ auswählen
- 3 Am Bedienpanel der Stromquelle „Information“ auswählen
- 4 Angezeigte IP-Adresse notieren (Beispiel: 10.5.72.13)

Website der Stromquelle im Internetbrowser aufrufen:

- 5 Computer mit dem Netzwerk der Stromquelle verbinden
- 6 IP-Adresse der Stromquelle in die Suchleiste des Internetbrowsers eingeben und bestätigen
- 7 Standard-Benutzernamen (admin) und Passwort (admin) eingeben
 - Website der Stromquelle wird angezeigt

Prozessdaten-Breite des Busmoduls einstellen:

- 8 Auf der Website der Stromquelle den Reiter „RI FB PRO/i“ auswählen
- 9 Bei Punkt „Prozessdaten“ die gewünschte Prozessdaten-Konfiguration auswählen
- 10 „Speichern“ auswählen
 - Die Feldbus-Verbindung wird neu gestartet und die Konfiguration übernommen

Ein- und Ausgangssignale

Datentypen

Folgende Datentypen werden verwendet:

- **UINT16** (Unsigned Integer)
Ganzzahl im Bereich von 0 bis 65535
- **SINT16** (Signed Integer)
Ganzzahl im Bereich von -32768 bis 32767

Umrechnungsbeispiele:

- für positiven Wert (SINT16)
z.B. gewünschter Drahtvorschub x Faktor
 $12.3 \text{ m/min} \times 100 = 1230_{\text{dez}} = 04\text{CE}_{\text{hex}}$
- für negativen Wert (SINT16)
z.B. gewünschte Lichtbogen-Korrektur x Faktor
 $-6.4 \times 10 = -64_{\text{dez}} = \text{FFCO}_{\text{hex}}$

Verfügbarkeit der Eingangssignale

Die nachfolgend angeführten Eingangssignale sind ab Firmware V1.7.0 des RI FB PRO/i verfügbar.

Eingangssignale (vom Roboter zur Stromquelle)

Adresse				Signal	Aktivität / Datentyp	Bereich	Faktor	Prozess-Image	
relativ		absolut						Standard	Economy
WORD	BYTE	BIT	BIT						
0	0	0	0	Welding Start	steigend			✓	✓
		1	1	Robot ready	High				
		2	2	Working mode Bit 0	High	Siehe Tabelle Wertebereich Working mode auf Seite 13			
		3	3	Working mode Bit 1	High				
		4	4	Working mode Bit 2	High				
		5	5	Working mode Bit 3	High				
		6	6	Working mode Bit 4	High				
	7	7	—						
	1	0	8	Gas on	steigend				
		1	9	Wire forward	steigend				
		2	10	Wire backward	steigend				
		3	11	Error quit	steigend				
		4	12	Touch sensing	High				
		5	13	Torch blow out	steigend				
		6	14	Processline selection Bit 0	High	Siehe Tabelle Wertebereich Processline selection auf Seite 14			
7	15	Processline selection Bit 1	High						
1	2	0	16	Welding Simulation	High				
		1	17	Synchro pulse on	High				
		2	18	—					
		3	19	—					
		4	20	—					
		5	21	—					
		6	22	Wire brake on	High				
	7	23	Torchbody Xchange	High					
	3	0	24	—					
		1	25	Teach mode	High				
		2	26	—					
		3	27	—					
		4	28	—					
		5	29	Wire sense start	steigend				
6		30	Wire sense break	steigend					
7	31	—							

Adresse				Signal	Aktivität / Datentyp	Bereich	Faktor	Prozess-Image	
relativ		absolut						Standard	Economy
WORD	BYTE	BIT	BIT						
2	4	0	32	TWIN mode Bit 0	High	Siehe Tabelle Wertebereich TWIN mode auf Seite 14	✓	✓	
		1	33	TWIN mode Bit 1	High				
		2	34	—					
		3	35	—					
		4	36	—					
		5	37	Documentation mode	High	Siehe Tabelle Wertebereich Documentation mode auf Seite 13			
		6	38	—					
		7	39	—					
	5	0	40	—					
		1	41	—					
		2	42	—					
		3	43	—					
		4	44	—					
		5	45	—					
6		46	—						
	7	47	Disable process controlled correction	High					

Adresse				Signal	Aktivität / Datentyp	Bereich	Faktor	Prozess-Image		
relativ		absolut						Standard	Economy	
WORD	BYTE	BIT	BIT							
3	6	0	48	—				✓	✓	
		1	49	—						
		2	50	—						
		3	51	—						
		4	52	—						
		5	53	—						
		6	54	—						
	7	55	—							
	7	0	56	ExtInput1 => OPT_Output 1	High					
		1	57	ExtInput2 => OPT_Output 2	High					
		2	58	ExtInput3 => OPT_Output 3	High					
		3	59	ExtInput4 => OPT_Output 4	High					
		4	60	ExtInput5 => OPT_Output 5	High					
		5	61	ExtInput6 => OPT_Output 6	High					
		6	62	ExtInput7 => OPT_Output 7	High					
7		63	ExtInput8 => OPT_Output 8	High						
4	8	0-7	64-71	Welding characteristic- / Job number	UINT16	0 bis 1000	1	✓	✓	
	9	0-7	72-79							
5	10, 11	0-7	80-95	<i>Beim Schweißverfahren MIG/MAG Puls-Synergic, MIG/MAG Standard-Synergic, MIG/MAG Standard-Manuell, MIG/MAG PMC, MIG/MAG LSC, CMT, ConstantWire:</i> Wire feed speed command value	SINT16	-327,68 bis 327,67 [m/min]	100	✓	✓	
				<i>Beim Job-Betrieb:</i> Power correction	SINT16	-20,00 bis 20,00 [%]	100			

Adresse				Signal	Aktivität / Datentyp	Bereich	Faktor	Prozess-Image	
relativ		absolut	Standard					Economy	
WORD	BYTE	BIT							
6	12, 13	0-7	96-111	<i>Beim Schweißverfahren MIG/MAG Puls-Synergic, MIG/MAG Standard-Synergic, MIG/MAG PMC, MIG/MAG LSC, CMT:</i> Arclength correction	SINT16	-10,0 bis 10,0 [Schritte]	10	✓	✓
				<i>Beim Schweißverfahren MIG/MAG Standard-Manuell:</i> Welding voltage	UINT16	0,0 bis 6553,5 [V]	10		
				<i>Beim Job-Betrieb:</i> Arclength correction	SINT16	-10,0 bis 10,0 [Schritte]	10		
				<i>Beim Schweißverfahren ConstantWire:</i> Hotwire current	UINT16	0,0 bis 6553,5 [A]	10		
7	14, 15	0-7	112-127	<i>Beim Schweißverfahren MIG/MAG Puls-Synergic, MIG/MAG Standard-Synergic, MIG/MAG PMC, MIG/MAG LSC, CMT:</i> Pulse-/dynamic correction	SINT16	-10,0 bis 10,0 [Schritte]	10	✓	✓
				<i>Beim Schweißverfahren MIG/MAG Standard-Manuell:</i> Dynamic	UINT16	0,0 bis 10,0 [Schritte]	10		
8	16	0-7	128-135	Wire retract correction	UINT16	0,0 bis 10,0 [Schritte]	10	✓	
	17	0-7	136-143						
9	18	0-7	144-151	Welding speed	UINT16	0,0 bis 1000,0 [cm/min]	10	✓	
	19	0-7	152-159						
10	20	0-7	160-167	Process controlled correction		Siehe Tabelle Wertebereich Process controlled correction auf Seite 14		✓	
	21	0-7	168-175						

Adresse				Signal	Aktivität / Datentyp	Bereich	Faktor	Prozess-Image	
relativ		absolut	Standard					Economy	
WORD	BYTE	BIT							
11	22	0-7	176-183	—				✓	
	23	0-7	184-191						
12	24	0-7	192-199	—				✓	
	25	0-7	200-207						
13	26	0-7	208-215	—				✓	
	27	0-7	216-223						
14	28	0-7	224-231	—				✓	
	29	0-7	232-239						
15	30	0-7	240-247	Wire forward / backward length	UINT16	OFF / 1 bis 65535 [mm]	1	✓	
	31	0-7	248-255						
16	32	0-7	256-263	Wire sense edge detection	UINT16	OFF / 0,5 bis 20,0 [mm]	10	✓	
	33	0-7	264-271						
17	34	0-7	272-279	—				✓	
	35	0-7	280-287						
18	36	0-7	288-295	—				✓	
	37	0-7	296-303						
19	38	0-7	304-311	Seam number	UINT16	0 bis 65535	1	✓	
	39	0-7	312-319						

Wertebereich Working mode

Bit 4	Bit 3	Bit 2	Bit 1	Bit 0	Beschreibung
0	0	0	0	0	Parameterwahl intern
0	0	0	0	1	Kennlinien Betrieb Sonder 2-Takt
0	0	0	1	0	Job-Betrieb
0	1	0	0	0	Kennlinien Betrieb 2-Takt
0	1	0	0	1	MIG/MAG Standard-Manuell 2-Takt
1	0	0	0	1	Kühlmittel-Pumpe stoppen

Wertebereich Betriebsart

Wertebereich Documentation mode

Bit 0	Beschreibung
0	Nahtnummer von Stromquelle (intern)
1	Nahtnummer von Roboter (Word 19)

Wertebereich Dokumentationsmodus

**Wertebereich
Process controlled correction**

Prozess	Signal	Aktivität / Datentyp	Wertebereich Einstellbereich	Einheit	Faktor
PMC	Arc length stabilizer	SINT16	-327,8 bis +327,7 0,0 bis +5,0	Volt	10

Wertebereich prozessabhängige Korrektur

**Wertebereich
Processline selection**

Bit 1	Bit 0	Beschreibung
0	0	Prozesslinie 1 (default)
0	1	Prozesslinie 2
1	0	Prozesslinie 3
1	1	Reserviert

Wertebereich Prozesslinien-Auswahl

**Wertebereich
TWIN mode**

Bit 1	Bit 0	Beschreibung
0	0	TWIN Single mode
0	1	TWIN Lead mode
1	0	TWIN Trail mode
1	1	Reserve

Wertebereich TWIN-Betriebsart

Verfügbarkeit der Ausgangssignale

Die nachfolgend angeführten Ausgangssignale sind ab Firmware V1.7.0 des RI FB PRO/i verfügbar.

Ausgangssignale (von der Stromquelle zum Roboter)

Adresse				Signal	Aktivität / Datentyp	Bereich	Faktor	Prozess-Image	
relativ		absolut						Standard	Economy
WORD	BYTE	BIT	BIT						
0	0	0	0	Heartbeat Powersource	High/Low	1 Hz			
		1	1	Power source ready	High				
		2	2	Warning	High				
		3	3	Process active	High				
		4	4	Current flow	High				
		5	5	Arc stable- / touch signal	High				
		6	6	Main current signal	High				
		7	7	Touch signal	High				
	1	0	8	Collisionbox active	Low	0 = Kollision oder Kabelbruch	✓	✓	
		1	9	Robot Motion Release	High				
		2	10	Wire stick workpiece	High				
		3	11	—					
		4	12	Short circuit contact tip	High				
		5	13	Parameter selection internally	High				
		6	14	Characteristic number valid	High				
7	15	Torch body gripped	High						

Adresse				Signal	Aktivität / Datentyp	Bereich	Faktor	Prozess-Image		
relativ		absolut						Standard	Economy	
WORD	BYTE	BIT	BIT							
1	2	0	16	Command value out of range	High			✓	✓	
		1	17	Correction out of range	High					
		2	18	—						
		3	19	Limitsignal	High					
		4	20	—						
		5	21	—						
		6	22	Main supply status	Low					
	7	23	—							
	3	0	24	Sensor status 1	High	Siehe Tabelle Zuordnung Sensorstatus 1-4 auf Seite 18				
		1	25	Sensor status 2	High					
		2	26	Sensor status 3	High					
		3	27	Sensor status 4	High					
		4	28	—						
		5	29	—						
6		30	—							
7	31	—								
2	4	0	32	—				✓	✓	
		1	33	—						
		2	34	—						
		3	35	Safety status Bit 0	High	Siehe Tabelle Wertebereich Safety status auf Seite 18				
		4	36	Safety status Bit 1	High					
		5	37	—						
		6	38	Notification	High					
	7	39	System not ready	High						
	5	0	40	—						
		1	41	—						
		2	42	—						
		3	43	—						
		4	44	—						
		5	45	—						
6		46	—							
7	47	—								

Adresse				Signal	Aktivität / Datentyp	Bereich	Faktor	Prozess-Image	
relativ		absolut						Standard	Economy
WORD	BYTE	BIT	BIT						
3	6	0	48	Process Bit 0	High	Siehe Tabelle Wertebereich Process Bit auf Seite 19			
		1	49	Process Bit 1	High				
		2	50	Process Bit 2	High				
		3	51	Process Bit 3	High				
		4	52	Process Bit 4	High				
		5	53	—					
	6	54	Touch signal gas nozzle	High					
	7	55	TWIN synchronization active	High					
	7	0	56	ExtOutput1 <= OPT_Input1	High				
		1	57	ExtOutput2 <= OPT_Input2	High			✓	✓
		2	58	ExtOutput3 <= OPT_Input3	High				
		3	59	ExtOutput4 <= OPT_Input4	High				
		4	60	ExtOutput5 <= OPT_Input5	High				
		5	61	ExtOutput6 <= OPT_Input6	High				
6		62	ExtOutput7 <= OPT_Input7	High					
7		63	ExtOutput8 <= OPT_Input8	High					
4	8	0-7	64-71	Welding voltage	UINT16	0,0 bis 655,35 [V]	100	✓	✓
	9	0-7	72-79						
5	10	0-7	80-87	Welding current	UINT16	0,0 bis 6553,5 [A]	10	✓	✓
	11	0-7	88-95						
6	12	0-7	96-103	Wire feed speed	SINT16	-327,68 bis 327,67 [m/min]	100	✓	✓
	13	0-7	104-111						
7	14	0-7	112-119	Actual real value for seam tracking	UINT16	0 bis 6,5535	10000	✓	✓
	15	0-7	120-127						
8	16	0-7	128-135	Error number	UINT16	0 bis 65535	1	✓	
	17	0-7	136-143						
9	18	0-7	144-151	Warning number	UINT16	0 bis 65535	1	✓	
	19	0-7	152-159						

Adresse				Signal	Aktivität / Datentyp	Bereich	Faktor	Prozess-Image				
relativ		absolut	WORD					BYTE	BIT	BIT	Standard	Economy
10	20	0-7	160-167	Motor current M1	SINT16	-327,68 bis 327,67 [A]	100	✓				
	21	0-7	168-175									
11	22	0-7	176-183	Motor current M2	SINT16	-327,68 bis 327,67 [A]	100	✓				
	23	0-7	184-191									
12	24	0-7	192-199	Motor current M3	SINT16	-327,68 bis 327,67 [A]	100	✓				
	25	0-7	200-207									
13	26	0-7	208-215	—				✓				
	27	0-7	216-223									
14	28	0-7	224-231	—				✓				
	29	0-7	232-239									
15	30	0-7	240-247	—				✓				
	31	0-7	248-255									
16	32	0-7	256-263	Wire position	SINT16	-327,68 bis 327,67 [mm]	100	✓				
	33	0-7	264-271									
17	34	0-7	272-279	—				✓				
	35	0-7	280-287									
18	36	0-7	288-295	—				✓				
	37	0-7	296-303									
19	38	0-7	304-311	—				✓				
	39	0-7	312-319									

Zuordnung Sensorstatus 1-4

Signal	Beschreibung
Sensor status 1	OPT/i WF R Drahtende (4,100,869)
Sensor status 2	OPT/i WF R Drahtfass (4,100,879)
Sensor status 3	OPT/i WF R Ringsensor (4,100,878)
Sensor status 4	Drahtpufferset CMT TPS/i (4,001,763)

Wertebereich Safety status

Bit 1	Bit 0	Beschreibung
0	0	Reserve
0	1	Halt
1	0	Stopp

Bit 1	Bit 0	Beschreibung
1	1	Nicht eingebaut / aktiv

**Wertebereich
Process Bit**

Bit 4	Bit 3	Bit 2	Bit 1	Bit 0	Beschreibung
0	0	0	0	0	kein Prozess oder Parameterwahl intern
0	0	0	0	1	MIG/MAG Puls-Synergic
0	0	0	1	0	MIG/MAG Standard-Synergic
0	0	0	1	1	MIG/MAG PMC
0	0	1	0	0	MIG/MAG LSC
0	0	1	0	1	MIG/MAG Standard-Manuell
0	0	1	1	0	Elektrode
0	0	1	1	1	WIG
0	1	0	0	0	CMT
0	1	0	0	1	ConstantWire

Table of contents

General.....	22
Safety.....	22
Connections and Indicators.....	22
Data Transfer Properties.....	23
Configuration Parameters.....	23
Assigning the EtherCAT Address.....	23
Set the Process Data Width of the Bus Module.....	24
Set the Process Data Width of the Bus Module.....	24
Input and output signals.....	25
Data types.....	25
Availability of Input Signals.....	25
Input Signals (From Robot to Power Source).....	25
Value Range for Working Mode.....	31
Value Range for Documentation Mode.....	31
Value range for Process controlled correction.....	32
Value range Process line selection.....	32
Value Range for TWIN Mode.....	32
Availability of Output Signals.....	33
Output Signals (from Power Source to Robot).....	33
Assignment of Sensor Statuses 1–4.....	36
Value range Safety status.....	36
Value Range for Process Bit.....	37

General

Safety

WARNING!

Danger from incorrect operation and work that is not carried out properly.

This can result in serious personal injury and damage to property.

- ▶ All the work and functions described in this document must only be carried out by technically trained and qualified personnel.
- ▶ Read and understand this document in full.
- ▶ Read and understand all safety rules and user documentation for this equipment and all system components.

Connections and Indicators

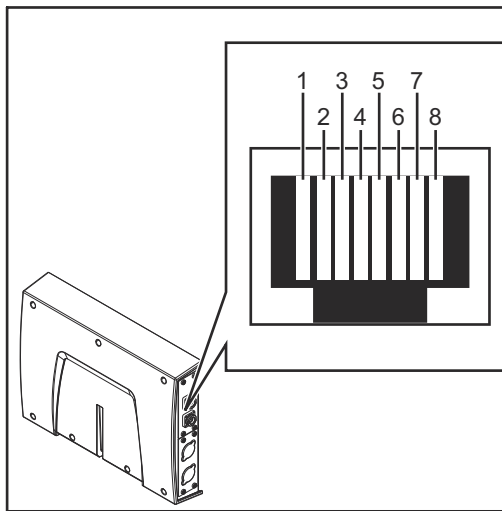

Pin assignment RJ45 ProfiNet connection

1	TX+
2	TX-
3	RX+
6	RX-
4,5,7,8	Not normally used; to ensure signal completeness, these pins must be interconnected and, after passing through a filter circuit, must terminate at the ground conductor (PE).

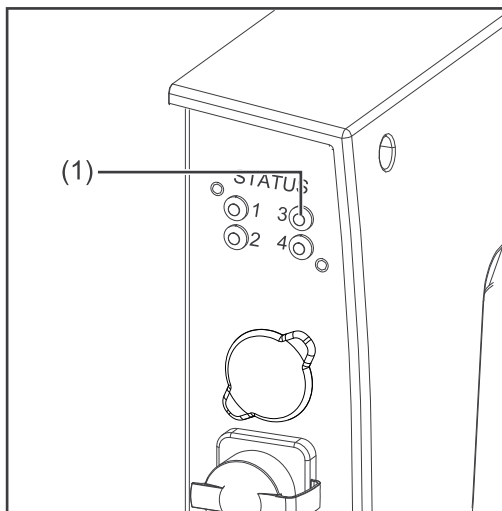

(1) RUN LED - operation
This LED indicates the status of the CoE communication. (CoE = CANopen over EtherCAT)

Off:

CoE device in 'init' status (or no supply voltage)

Lights up green:

CoE device in 'operational' status

Flashes green:

CoE device in 'pre-operational' status

Flashes green (briefly):

CoE device in 'safe-operational' status

Lights up red:

If the RUN LED and ERR LED light up red, this indicates a serious event which places the interface in an exception state. In this case, inform the service team.

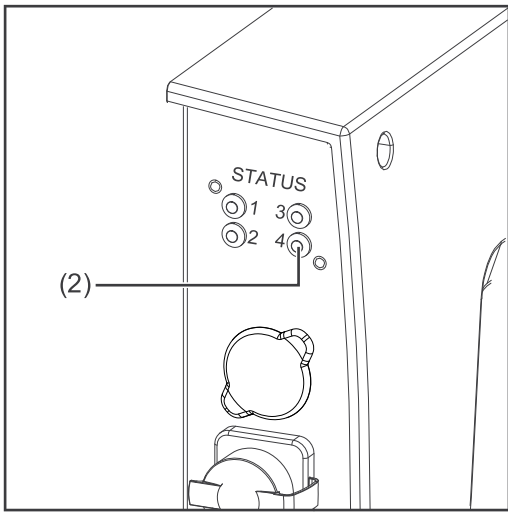

(2) ERR LED - error
Off: No error (or no supply voltage)
Flashes red: Incorrect configuration The status change received from the master is not possible due to invalid register or object settings
Flashes red (twice): Application watchdog timeout Syn manager watchdog timeout
Lights up red: Application controller failure Anybus module in EXCEPTION

Data Transfer Properties

Transfer technology: EtherCAT
Medium: When selecting the cable, plug, and terminating resistors, the IEC 61784-5-12 for the planning and installation of EtherCAT systems must be observed. The EMC tests were carried out by the manufacturer with an original Beckhoff cable (ZK1090-9191-xxxx).
Transmission speed: 100 Mbit/s
Bus connection: RJ45 Ethernet
Application layer: CANopen

Configuration Parameters

In some robot control systems, it may be necessary to state the configuration parameters described here so that the bus module can communicate with the robot.

Parameter	Value	Description
Vendor ID	0000 02C1 _{hex} (705 _{dec})	Fronius International GmbH
Product Code	0001 0322 _{hex} (66338 _{dec}) 0001 0321 _{hex} (66337 _{dec})	Standard Image Economy Image
Device Name		Fronius-RI-FB-Pro-EtherCAT

Assigning the EtherCAT Address

The EtherCAT address is assigned by the master.

Set the Process Data Width of the Bus Module

Set the Process Data Width of the Bus Module

Note down the IP address of the power source used:

- 1 On the power source control panel, select "Presets"
- 2 On the power source control panel, select "System"
- 3 On the power source control panel, select "Information"
- 4 Note down the displayed IP address (example: 10.5.72.13)

Access website of the power source in the internet browser:

- 5 Connect computer with the network of the power source
- 6 Enter the IP address of the power source in the search bar of the Internet browser and confirm
- 7 Enter standard user name (admin) and password (admin)
 - The website of the power source is displayed

Set the process data width of the bus module:

- 8 On the power source website, select the "RI FB PRO/i" tab
- 9 Under the "Process data" point, select the desired process data configuration
- 10 Select "Save"
 - The field bus connection is restarted and the configuration is adopted

Input and output signals

Data types

The following data types are used:

- **UINT16** (Unsigned Integer)
Whole number in the range from 0 to 65535
- **SINT16** (Signed Integer)
Whole number in the range from -32768 to 32767

Conversion examples:

- for a positive value (SINT16)
e.g. desired wire speed x factor
 $12.3 \text{ m/min} \times 100 = 1230_{\text{dec}} = 04\text{CE}_{\text{hex}}$
- for a negative value (SINT16)
e.g. arc correction x factor
 $-6.4 \times 10 = -64_{\text{dec}} = \text{FFC0}_{\text{hex}}$

Availability of Input Signals

The input signals listed below are available as of firmware V1.7.0 of the RI FB PRO/i.

Input Signals (From Robot to Power Source)

Address				Signal	Activity / data type	Range	Factor	Process image	
relative		absolute						Standard	Economy
WORD	BYTE	BIT	BIT						
0	0	0	0	Welding Start	Increasing			✓	✓
		1	1	Robot ready	High				
		2	2	Working mode Bit 0	High	See table Value Range for Working Mode on page 31			
		3	3	Working mode Bit 1	High				
		4	4	Working mode Bit 2	High				
		5	5	Working mode Bit 3	High				
		6	6	Working mode Bit 4	High				
	7	7	—						
	1	0	8	Gas on	Increasing				
		1	9	Wire forward	Increasing				
		2	10	Wire backward	Increasing				
		3	11	Error quit	Increasing				
		4	12	Touch sensing	High				
		5	13	Torch blow out	Increasing				
		6	14	Process line selection Bit 0	High	See table Value range Process line selection on page 32			
7		15	Process line selection Bit 1	High					

Address				Signal	Activity / data type	Range	Factor	Process image	
relative		absolute						Standard	Economy
WORD	BYTE	BIT	BIT						
1	2	0	16	Welding Simulation	High			✓	✓
		1	17	Synchro pulse on	High				
		2	18	—					
		3	19	—					
		4	20	—					
		5	21	—					
		6	22	Wire brake on	High				
	7	23	Torchbody Xchange	High					
	3	0	24	—					
		1	25	Teach mode	High				
		2	26	—					
		3	27	—					
		4	28	—					
		5	29	Wire sense start	Increasing				
6		30	Wire sense break	Increasing					
		7	31	—					

Address				Signal	Activity / data type	Range	Factor	Process image	
relative		absolute						Standard	Economy
WORD	BYTE	BIT	BIT						
2	4	0	32	TWIN mode Bit 0	High	See table Value Range for TWIN Mode on page 32	✓	✓	
		1	33	TWIN mode Bit 1	High				
		2	34	—					
		3	35	—					
		4	36	—					
		5	37	Documentation mode	High	See table Value Range for Documentation Mode on page 31			
		6	38	—					
		7	39	—					
	5	0	40	—					
		1	41	—					
		2	42	—					
		3	43	—					
		4	44	—					
		5	45	—					
6		46	—						
	7	47	Disable process controlled correction	High					

Address				Signal	Activity / data type	Range	Factor	Process image	
relative		absolute						Standard	Economy
WORD	BYTE	BIT	BIT						
3	6	0	48	—				✓	✓
		1	49	—					
		2	50	—					
		3	51	—					
		4	52	—					
		5	53	—					
		6	54	—					
	7	55	—						
	7	0	56	ExtInput1 => OPT_Output 1	High				
		1	57	ExtInput2 => OPT_Output 2	High				
		2	58	ExtInput3 => OPT_Output 3	High				
		3	59	ExtInput4 => OPT_Output 4	High				
		4	60	ExtInput5 => OPT_Output 5	High				
		5	61	ExtInput6 => OPT_Output 6	High				
6		62	ExtInput7 => OPT_Output 7	High					
7	63	ExtInput8 => OPT_Output 8	High						
4	8	0-7	64-71	Welding characteristic- / Job number	UINT16	0 to 1000	1		
	9	0-7	72-79						
5	10, 11	0-7	80-95	With the welding process MIG/MAG pulse synergic, MIG/MAG standard synergic, MIG/MAG standard manual, MIG/MAG PMC, MIG/MAG LSC, CMT, ConstantWire: Wire feed speed command value	SINT16	-327.68 to 327.67 [m/min]	100		
				With the Job mode: Power correction	SINT16	-20.00 to 20.00 [%]	100		

Address				Signal	Activity / data type	Range	Factor	Process image	
relative		absolute	Standard					Economy	
WORD	BYTE	BIT							
6	12, 13	0-7	96-111	With the welding process MIG/MAG pulse synergic, MIG/MAG standard synergic, MIG/MAG PMC, MIG/MAG LSC, CMT: Arclength correction	SINT16	-10.0 to 10.0 [Steps]	10		
				With the welding process MIG/MAG standard manual: Welding voltage	UINT16	0.0 to 6553.5 [V]	10	✓	✓
				With the Job mode: Arclength correction	SINT16	-10.0 to 10.0 [Steps]	10		
				With the welding process ConstantWire: Hotwire current	UINT16	0.0 to 6553.5 [A]	10		
7	14, 15	0-7	112-127	With the welding process MIG/MAG pulse synergic, MIG/MAG standard synergic, MIG/MAG PMC, MIG/MAG LSC, CMT: Pulse-/dynamic correction	SINT16	-10.0 to 10.0 [Steps]	10	✓	✓
				With the welding process MIG/MAG standard manual: Dynamic	UINT16	0.0 to 10.0 [Steps]	10		
8	16	0-7	128-135	Wire retract correction	UINT16	0.0 to 10.0 [Steps]	10	✓	
	17	0-7	136-143						
9	18	0-7	144-151	Welding speed	UINT16	0.0 to 1000.0 [cm/min]	10	✓	
	19	0-7	152-159						
10	20	0-7	160-167	Process controlled correction		See table Value range for Process controlled correction on page 32		✓	
	21	0-7	168-175						
11	22	0-7	176-183	—				✓	
	23	0-7	184-191						

Address				Signal	Activity / data type	Range	Factor	Process image	
relative		absolute	Standard					Economy	
WORD	BYTE	BIT							
12	24	0-7	192-199	—				✓	
	25	0-7	200-207						
13	26	0-7	208-215	—				✓	
	27	0-7	216-223						
14	28	0-7	224-231	—				✓	
	29	0-7	232-239						
15	30	0-7	240-247	Wire forward / backward length	UINT16	OFF / 1 to 65535 [mm]	1	✓	
	31	0-7	248-255						
16	32	0-7	256-263	Wire sense edge detection	UINT16	OFF / 0.5 to 20.0 [mm]	10	✓	
	33	0-7	264-271						
17	34	0-7	272-279	—				✓	
	35	0-7	280-287						
18	36	0-7	288-295	—				✓	
	37	0-7	296-303						
19	38	0-7	304-311	Seam number	UINT16	0 to 65535	1	✓	
	39	0-7	312-319						

Value Range for Working Mode

Bit 4	Bit 3	Bit 2	Bit 1	Bit 0	Description
0	0	0	0	0	Internal parameter selection
0	0	0	0	1	Special 2-step mode characteristics
0	0	0	1	0	Job mode
0	1	0	0	0	2-step mode characteristics
0	1	0	0	1	2-step MIG/MAG standard manual
1	0	0	0	1	Stop coolant pump

Value range for operating mode

Value Range for Documentation Mode

Bit 0	Description
0	Seam number of power source (internal)
1	Seam number of robot (Word 19)

Value range for documentation mode

Value range for Process controlled correction

Process	Signal	Activity / data type	Value range configuration range	Unit	Factor
PMC	Arc length stabilizer	SINT16	-327.8 to +327.7 0.0 to +5.0	Volts	10

Value range for process-dependent correction

Value range Process line selection

Bit 1	Bit 0	Description
0	0	Process line 1 (default)
0	1	Process line 2
1	0	Process line 3
1	1	Reserved

Value range for process line selection

Value Range for TWIN Mode

Bit 1	Bit 0	Description
0	0	TWIN Single mode
0	1	TWIN Lead mode
1	0	TWIN Trail mode
1	1	Reserved

Value range for TWIN mode

Availability of Output Signals

The output signals listed below are available as of firmware V1.7.0 of the RI FB PRO/i.

**Output Signals
(from Power Source to Robot)**

Address				Signal	Activity / data type	Range	Factor	Process image	
relative		absolute						Standard	Economy
WORD	BYTE	BIT	BIT						
0	0	0	0	Heartbeat Powersource	High/Low	1 Hz			
		1	1	Power source ready	High				
		2	2	Warning	High				
		3	3	Process active	High				
		4	4	Current flow	High				
		5	5	Arc stable- / touch signal	High				
		6	6	Main current signal	High				
		7	7	Touch signal	High				
	1	0	8	Collisionbox active	Low	0 = collision or cable break		✓	✓
		1	9	Robot Motion Release	High				
		2	10	Wire stick workpiece	High				
		3	11	—					
		4	12	Short circuit contact tip	High				
		5	13	Parameter selection internally	High				
		6	14	Characteristic number valid	High				
	7	15	Torch body gripped	High					

Address				Signal	Activity / data type	Range	Factor	Process image		
relative		absolute						Standard	Economy	
WORD	BYTE	BIT	BIT							
1	2	0	16	Command value out of range	High			✓	✓	
		1	17	Correction out of range	High					
		2	18	—						
		3	19	Limitsignal	High					
		4	20	—						
		5	21	—						
		6	22	Main supply status	Low					
	7	23	—							
	3	0	24	Sensor status 1	High	See table Assignment of Sensor Statuses 1–4 on page 36				
		1	25	Sensor status 2	High					
		2	26	Sensor status 3	High					
		3	27	Sensor status 4	High					
		4	28	—						
		5	29	—						
6		30	—							
2	4	0	32	—						
		1	33	—						
		2	34	—						
		3	35	Safety status Bit 0	High	See table Value range Safety status on page 36				
		4	36	Safety status Bit 1	High					
		5	37	—						
		6	38	Notification	High					
		7	39	System not ready	High					
	5	0	40	—						
		1	41	—						
		2	42	—						
		3	43	—						
		4	44	—						
		5	45	—						
6		46	—							
7	47	—								

Address				Signal	Activity / data type	Range	Factor	Process image	
relative		absolute						Standard	Economy
WORD	BYTE	BIT	BIT						
3	6	0	48	Process Bit 0	High	See table Value Range for Process Bit on page 37			
		1	49	Process Bit 1	High				
		2	50	Process Bit 2	High				
		3	51	Process Bit 3	High				
		4	52	Process Bit 4	High				
		5	53	—					
		6	54	Touch signal gas nozzle	High				
	7	55	TWIN synchronization active	High					
	7	0	56	ExtOutput1 <= OPT_Input1	High			✓	✓
		1	57	ExtOutput2 <= OPT_Input2	High				
		2	58	ExtOutput3 <= OPT_Input3	High				
		3	59	ExtOutput4 <= OPT_Input4	High				
		4	60	ExtOutput5 <= OPT_Input5	High				
		5	61	ExtOutput6 <= OPT_Input6	High				
6		62	ExtOutput7 <= OPT_Input7	High					
7		63	ExtOutput8 <= OPT_Input8	High					
4	8	0-7	64-71	Welding voltage	UINT16	0.0 to 655.35 [V]	100	✓	✓
	9	0-7	72-79						
5	10	0-7	80-87	Welding current	UINT16	0.0 to 6553.5 [A]	10	✓	✓
	11	0-7	88-95						
6	12	0-7	96-103	Wire feed speed	SINT16	-327.68 to 327.67 [m/min]	100	✓	✓
	13	0-7	104-111						
7	14	0-7	112-119	Actual real value for seam tracking	UINT16	0 to 6.5535	10000	✓	✓
	15	0-7	120-127						
8	16	0-7	128-135	Error number	UINT16	0 to 65535	1	✓	
	17	0-7	136-143						
9	18	0-7	144-151	Warning number	UINT16	0 to 65535	1	✓	
	19	0-7	152-159						

Address				Signal	Activity / data type	Range	Factor	Process image	
relative		absolute	Standard					Economy	
WORD	BYTE	BIT							
10	20	0-7	160-167	Motor current M1	SINT16	-327.68 to 327.67 [A]	100	✓	
	21	0-7	168-175						
11	22	0-7	176-183	Motor current M2	SINT16	-327.68 to 327.67 [A]	100	✓	
	23	0-7	184-191						
12	24	0-7	192-199	Motor current M3	SINT16	-327.68 to 327.67 [A]	100	✓	
	25	0-7	200-207						
13	26	0-7	208-215	—				✓	
	27	0-7	216-223						
14	28	0-7	224-231	—				✓	
	29	0-7	232-239						
15	30	0-7	240-247	—				✓	
	31	0-7	248-255						
16	32	0-7	256-263	Wire position	SINT16	-327.68 to 327.67 [mm]	100	✓	
	33	0-7	264-271						
17	34	0-7	272-279	—				✓	
	35	0-7	280-287						
18	36	0-7	288-295	—				✓	
	37	0-7	296-303						
19	38	0-7	304-311	—				✓	
	39	0-7	312-319						

Assignment of Sensor Statuses 1–4

Signal	Description
Sensor status 1	OPT/i WF R wire end (4,100,869)
Sensor status 2	OPT/i WF R wire drum (4,100,879)
Sensor status 3	OPT/i WF R ring sensor (4,100,878)
Sensor status 4	Wire buffer set CMT TPS/i (4,001,763)

Value range Safety status

Bit 1	Bit 0	Description
0	0	Reserve
0	1	Hold
1	0	Stop
1	1	Not installed / active

Value Range for Process Bit

Bit 4	Bit 3	Bit 2	Bit 1	Bit 0	Description
0	0	0	0	0	No internal parameter selection or process
0	0	0	0	1	MIG/MAG pulse synergic
0	0	0	1	0	MIG/MAG standard synergic
0	0	0	1	1	MIG/MAG PMC
0	0	1	0	0	MIG/MAG LSC
0	0	1	0	1	MIG/MAG standard manual
0	0	1	1	0	Electrode
0	0	1	1	1	TIG
0	1	0	0	0	CMT
0	1	0	0	1	ConstantWire



Fronius International GmbH

Froniusstraße 1
4643 Pettenbach
Austria
contact@fronius.com
www.fronius.com

At www.fronius.com/contact you will find the contact details
of all Fronius subsidiaries and Sales & Service Partners.